

2011 HOT STREET STOCK SEMIS INTERSTATE PULLERS

This class is for STREET LEGAL and STREET LICENSED semi trucks - Not Pure Stock.

LEGALITY OF ENTRY

All entries must be a Street Licensed Semi Truck. The owner must furnish a current registration card for the vehicle at the time of registration and the driver must have a valid CDL license. Truck must be capable of pulling a trailer on the highway. All trucks must be members of Interstate Pullers (\$30.00) to be eligible for points.

SAFETY CONSIDERATIONS

No riders, pets, or objects of any kind are permitted in truck during pull attempt or in staging area. Driver may not leave the driver's seat while vehicle is on the pulling track. Driver will take all direction from the flagman on the track. Driver must use a seatbelt and shoulder harness when hooked to the sled. All drivers must remain in seat while trucks are started.

HITCHES

Hitch height will be Max. 22" at all pulls. Hitch must work from the fifth wheel with the fifth wheel centered between center line of front axle to the center between the two axles. Hitches will be measured at the hook of sled and at the unhook of the sled. Hitches MUST meet safety requirements. Trucks pulling must have their own hitches unless arrangements are made prior to the pull. Promoter is not responsible for having hitches. Hitches will have to have at least a ½" chain welded to the back of the hitch to hang to the ground must measure 22"

(must be able to add and take off links) same as hitch height.

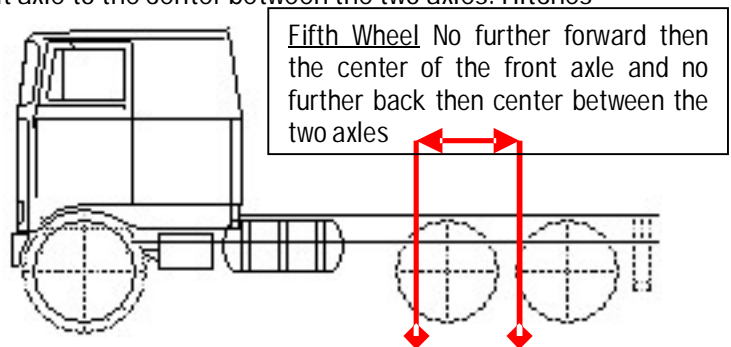

AIR BAGS

The use of air bags is permitted. However no air may be added to or removed from the air bags while the truck is hooked to the weight transfer machine, anyone caught will be disqualified. The height of the hitch must remain the same from start to finish. Any change in the hitch height will be cause for disqualification. Anyone caught dumping air will be automatically disqualified. No modifications of airlines or dump valves will be permitted, stock only. A ½" chain must be welded to back of hitch to hang to ground 22" and must be able to add and remove links.

WEIGHT OF TRUCK (22,000 LB. MAXIMUM)

The truck shall appear 'road ready'. No added weight or ballast is permitted. Special trucks, such as oil field trucks that carry additional weight that is not normally found on a 'road ready' truck are not permitted in this class. The promoter may weigh any truck at any time. Trucks with triple (3) rear axles are not permitted to participate in this class.

SPECIAL RULES

Chaining or blocking of drive axles is not permitted. No more than 2 turbos on any make of engine. Water Injection in any form is not permitted. No ether, alcohol, nitrous or other combustible (propellant) liquid or combustible material may be injected into the turbocharger or any part of the air intake system. Alterations/Modification/Replacement of the (OEM) original factory fuel pump is not permitted. No pump may be modified with Sigma parts. A Cummins engine must have a Cummins fuel pump-A Detroit must have a Detroit fuel pump – A Cat must have a Cat fuel pump. Normal pump diesel is the only fuel permitted in this class. Electronic engines must remain electronic. No mechanical fuel pumps permitted on electronic engines.

1. There must be 46" from the center of the tandems to the first obstruction forward such as the back of the truck cab, toolbox, wet line box, etc.
2. Tandem axle spacing must be between 60" and 52"

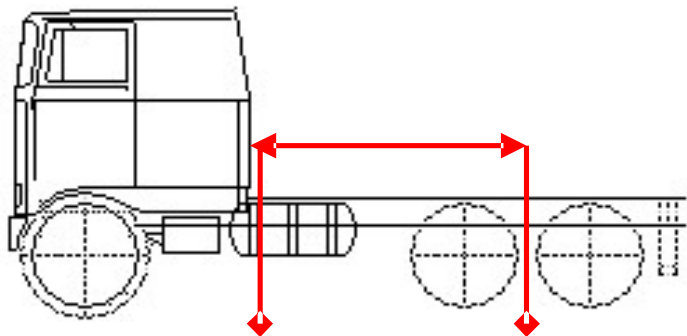

Must have a minimum of 46" from center of tandems to first structural obstruction such as the bunk, toolbox, cab, etc. This is the minimum swing clearance needed to pull a trailer.